

### Features

- Rite-Temp® pressure-balancing diaphragm design
- Pressure-balancing mechanism of one-piece diaphragm cartridge design for ease of maintenance
- Mixing valve cycles from "cold" to "hot"
- Integral diverter mechanism
- High-temperature limit setting for added safety
- Available with or without screwdriver stops
- Designed for showerhead and handshower applications

### Material

- Brass valve bodies



### Codes/Standards

ASME A112.18.1/CSA B125.1  
ASSE 1016/ASME A112.1016/CSA B125.16  
California Energy Commission (CEC)  
NOM Standards  
NOM 012-CONAGUA

### KOHLER® Faucet Lifetime Limited Warranty

See website for detailed warranty information.

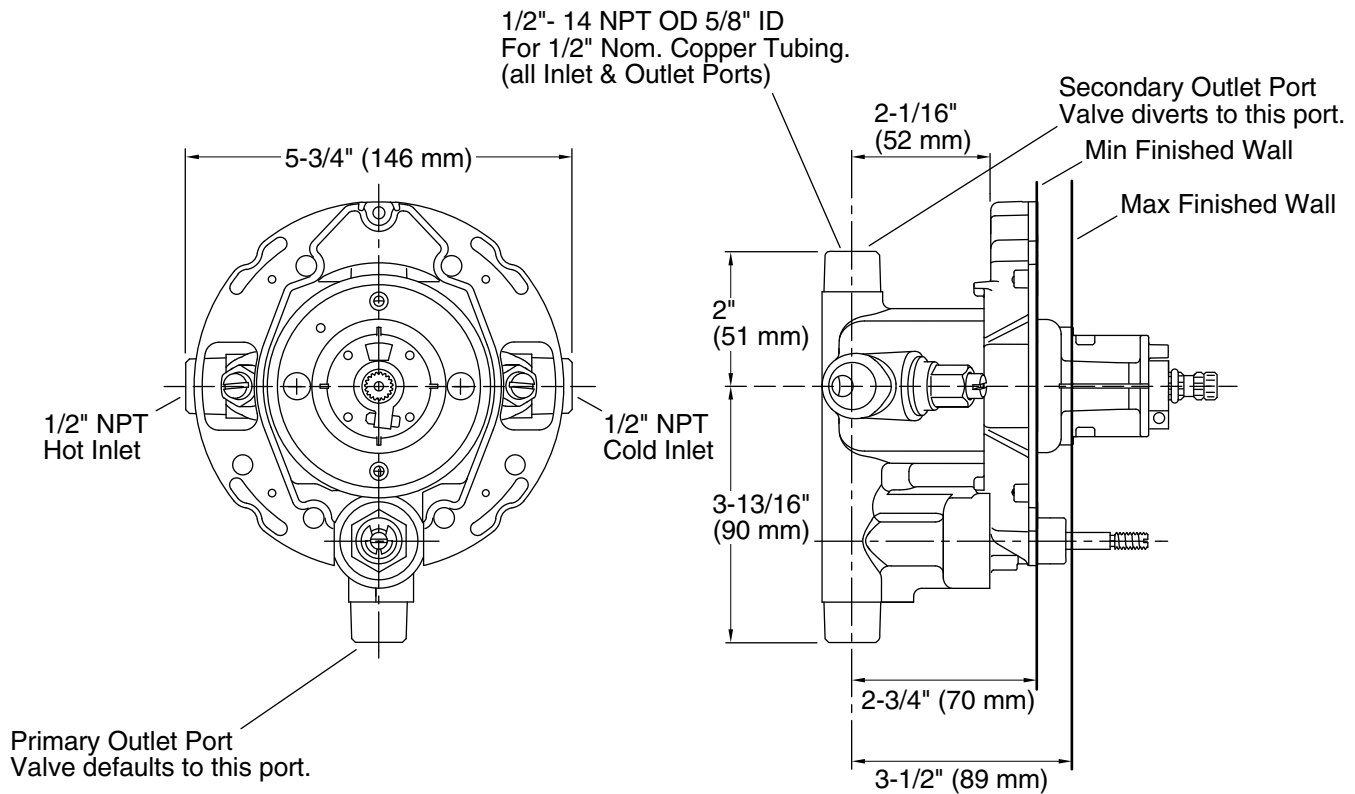

### Technical Information

All product dimensions are nominal.

#### Spout:

#### Shower Valve:

|                               |                        |
|-------------------------------|------------------------|
| Flow Rate (Max) @ 45 psi      | 5 gal/min (18.9 l/min) |
| Pressure:                     | 45 psi (3.1 bar)       |
| Maximum (Static) Pressure:    | 125 psi (8.6 bar)      |
| Minimum (Operating) Pressure: | 20 psi (1.4 bar)       |

### Notes

Install this product according to the installation instructions.

For use with showerheads or handsprays rated at 0 gal/min (0 l/min) or higher.