



# Branham™

Full stall washout urinal with rear spud  
K-25039-R

## Features

- Full-stall wash-down urinal
- 0.5 or 1.0 gpf (1.9 or 3.8 lpf)
- Lip of urinal installs below floor level for easier cleaning around fixture
- Full length sidewalls provide added privacy
- External trapway
- 3/4" (19 mm) rear spud
- Drain sold separately

## Material

- Vitreous china

## Installation

- Replaces K-4920-R

## Required Products/Accessories

K-9172 Urinal Strainer

or

K-9183 Urinal Strainer



|     |          |     |
|-----|----------|-----|
| ADA | CSA B651 | OBC |
|-----|----------|-----|

## Codes/Standards

ASME A112.19.2/CSA B45.1  
DOE - Energy Policy Act 1992  
EPA WaterSense®  
California Energy Commission (CEC)  
ADA  
ICC/ANSI A117.1  
CSA B651  
OBC

## KOHLER® One-Year Limited Warranty

See website for detailed warranty information.

## Available Colors/Finishes

*Color tiles intended for reference only.*

| Color | Code | Description |
|-------|------|-------------|
|-------|------|-------------|

|   |   |       |
|---|---|-------|
|  | 0 | White |
|---|---|-------|

1-800-4KOHLER (1-800-456-4537)

Kohler Co. reserves the right to make revisions without notice to product specifications.

For the most current Specification Sheet, go to [www.kohler.com](http://www.kohler.com) USA or [www.kohler.ca](http://www.kohler.ca) Canada

1-26-2026 19:41 - US/CA

THE BOLD LOOK  
OF **KOHLER**®

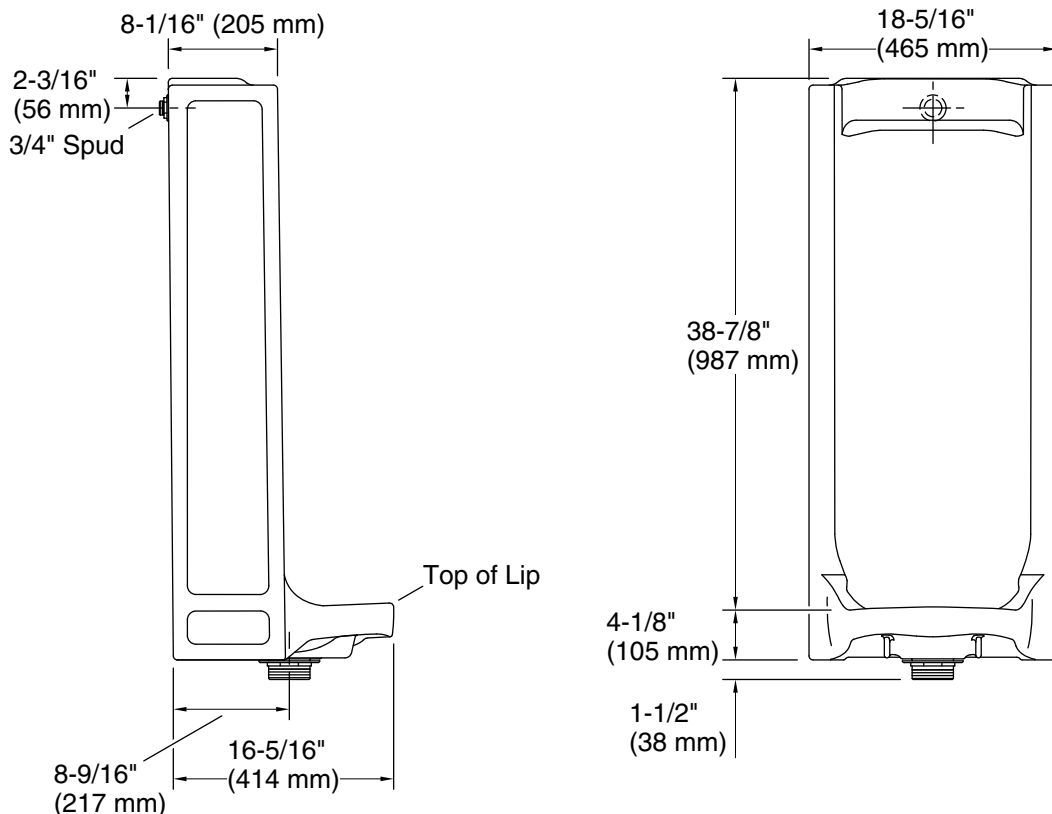

## Technical Information

All product dimensions are nominal.

|                       |                   |
|-----------------------|-------------------|
| Flush Type:           | Washout           |
| Spud size:            | 3/4", Inlet, Rear |
| Min. Water per Flush: | 0.5 gpf (1 lpf)   |
| Max. Water per Flush: | 1 gpf (3.8 lpf)   |

Designed for the above water use when installed with a water-saving flushometer.

## Pressure and Supply Requirements

|                                |                    |
|--------------------------------|--------------------|
| Fixture pressure min (static): | 20 psi (137.9 kPa) |
| Fixture pressure max (static): | 80 psi (551.6 kPa) |

## Notes

Install this product according to the installation instructions.

Refer to manufacturer's instructions and local codes for flushometer requirements.

Product dimensions are nominal and may vary per ASME A112.19.2 tolerances.

This product should be used with a WaterSense labeled counterpart with the same rated flush volume to ensure the complete system meets the requirements of this specification for water efficiency and performance.

ADA, OBC, CSA B651 compliant when installed to the specific requirements of these regulations.